

## CPL190 • CPL290



Last update: 2022-05-13

---

## Table of Contents

1	APPROVAL AND SAFETY CONSIDERATIONS	3
2	HELPFUL TECHNICAL SUPPORT DOCUMENTS ONLINE	4
3	DESCRIPTION	5
4	BASIC OPERATION	5
5	MAKING A BASIC MEASUREMENT	5
6	INTERPRETING THE OUTPUT VOLTAGE	6
7	FRONT PANEL CONTROLS, INDICATORS AND CONNECTORS	6
8	MULTIPLE CHANNEL MEASUREMENTS	7
8.1	CPL190/290 SPECIFICATIONS <sup>1</sup>	7
9	CHANGING CPL190/290/490 BANDWIDTH SETTINGS	8
10	ELITE SERIES ENCLOSURES	9
11	EN191, EN192, EN193 POWER CONNECTOR	10
12	DAQ CONNECTOR PINOUT	11
13	MECHANICAL SPECIFICATIONS: EN196, EN198	12
14	AIR-BEARING C-LVDT: CAPACITIVE LVDT - TYPE CONTACT SENSOR	14
15	AIR-BEARING C-LVDT: MECHANICAL DETAIL	15

Last update: 2022-05-13

---

## 1 Approval and safety considerations

The Elite Series is compliant with the following CE standards: Safety: EN 61010-1:2010

EMC: IEC 61326-1:2013, IEC 61326-2-3:2013

To maintain compliance with these standards, the following operating conditions must be maintained:

- All I/O connecting cables must be shielded and less than three meters in length
- AC power cables must be rated at a minimum of 250 V and 5 A
- AC power must be connected to a grounded mains outlet rated less than 20A
- Use the included CE approved power supply with 1-, 2-, and 3- slot enclosures. If an alternative power supply is used, it must have equivalent CE certification and provide safety isolation from the mains according to IEC60950 or 61010.
- Sensors must not be attached to parts operating at hazardous voltages in excess of 33VRMS or 70VDC

Use of the equipment in any other manner may impair its safety and EMI protections.

### Probe Tip Contact Caution

**CAUTION:** *The sensing tips of capacitive probes produce voltages as high as 70 Vrms. These are high frequency voltages with very low power so they pose no danger. Normally when the probe tip is touched, the probe stops functioning and voltage is reduced to near zero. But under certain circumstances, the voltage may cause a slight tingle or burning sensation, especially with the second generation probes used with the CPL490. For maximum performance probe tips should remain free of oils or other contaminants.*

*For these reasons, it is recommended the probe tips not be touched.*

Last update: 2022-05-13

---

## 2 Helpful Technical Support Documents Online

The IBS Precision Engineering's website has a large selection of technical documents (TechNotes and Application Notes) in the Technical Library. These documents provide detailed descriptions of the operation and use of the products of IBS Precision Engineering.

The Technical Library can be accessed at:

<https://www.ibspe.com/expertise/technical-resources>

Some of the titles include:

- Understanding Capacitive and Inductive Sensors
- Comparing Capacitive and Inductive Sensors
- Z-height Measurement with Non-contact Sensors
- Sensor Operation and Optimization
- Using Capacitive Sensors in Vacuum Applications
- Understanding Electrical Runout When Using an Eddy-Current Sensor for Roundness Measurements
- Inductive Probe Cabling Considerations

Last update: 2022-05-13

---

### 3 Description

The CPL190/290 Capacitive Sensor is a precision, noncontact measurement device. The output voltage changes in direct linear proportion to changes in the gap between the probe and the target. The sensor is normally used to measure conductive targets, but it can also be used with nonconductive targets under the right conditions. For more information about measuring non-conductors, visit the Technical Library at [www.lionprecision.com](http://www.lionprecision.com) or call for assistance.

The CPL190/290 works with most Standard Probes.

### 4 Basic Operation

The output voltage is accessed via the front panel BNC connector, or by a data acquisition system via the high-density connector on the rear of the enclosure. This connector can connect directly to National Instruments™ data acquisition products. See the enclosure section of this manual for specifics on the system DAQ connector (page 11).

As the gap between the probe and target changes, the output voltage will change accordingly. As the probe approaches the target, the output voltage will become more positive.

*Note: Calibrated Range “Near” and “Far” lights (red) indicate that the probe is out of its calibrated range and the output is not guaranteed to be accurate even though the voltage may be in range and continue to change.*

Probes are calibrated to specific modules. With multiple channel systems, be sure the number on the probe cable (near the connector) matches the number on the module handle.

The CPL290 provides low and high sensitivity calibrations for a single probe. Use the Sensitivity switch to select the desired sensitivity. Calibration detail is provided on calibration sheets shipped with the product.

Noncontact sensors normally measure changes from a reference position.

### 5 Making a basic measurement

1. Connect probe to module
2. Set the target to a reference position or condition
3. Mount probe near target
4. Adjust the probe position until the “Calibrated Range” indicator is at center position
5. Use the Zero adjustments to adjust the output voltage to zero (optional)
6. As the probe/target gap changes, the output voltage will change accordingly

Last update: 2022-05-13

---

## 6 Interpreting the output voltage

The amount of change of the output voltage for a given change in the probe/target gap is called Sensitivity. The sensitivity of the sensor is listed on the calibration sheets which arrived with the sensor.

### Change in gap calculation:

Gap Change = Voltage Change / Sensitivity

For example: With a sensitivity of 1 V/2  $\mu\text{m}$  and a voltage change of 3 V, the gap change would be 6  $\mu\text{m}$  (3/0.5).

## 7 Front panel controls, indicators and connectors

### Zero Adjust

Adjusts the analog output voltage after the probe is initially positioned. Typically, the analog output voltage is adjusted to zero volts at range center. There is a coarse adjustment ( $\pm 10$  VDC), the outer control, and a fine adjustment ( $\pm 1$  VDC), the inner control. When the Zero switch is in the off position, the zero adjustment has no effect.

### Sensitivity (CPL290 Only)

The CPL290 provides a high-sensitivity and a low-sensitivity calibration for one probe. Refer to the calibration sheets for specific calibration information. Select the desired sensitivity with this switch.

Switching sensitivities will usually require repositioning the probe.

### Calibrated Range Indicator

Green LEDs indicate that the probe is in its calibrated range and the output voltage is an accurate representation of the target position. Red LEDs indicate that the probe is out of range and the output voltage is not valid.

The Calibrated Range Indicator is not affected by the Zero adjustment. The module is factory calibrated to zero volts at range center, however, it is possible to adjust the output voltage to zero while the probe is positioned toward the end of the calibrated range. In this situation, the probe can go out of its calibrated range while the output voltage continues to appear valid. The output voltage may continue to change, but the output is no longer guaranteed to be accurate. In this condition, the output voltage may appear valid but the Calibrated Range Indicator will be red. Out-of-Range indicator signals available through the system DAQ connector are activated anytime the Calibrated Range Indicator is red.

### Analog Output

Provides connection to the analog output voltage, which is proportional to the distance between the probe and the surface of the material being measured. A typical output voltage range is  $\pm 10$  VDC. The specific ranges are listed on the accompanying calibration sheets.

The analog output provided on the data acquisition (DAQ) connector on the rear of the enclosure is differential. See the enclosure section of this manual for specifics on the system DAQ connector.

Last update: 2022-05-13

## Ground

A banana-plug cable can be connected here for grounding the target. In most cases, separate grounding of the target is not necessary. If the target is not grounded through another path, and the output exhibits excessive electrical noise, grounding the target may reduce the output noise. When low-noise operation is critical, separate grounding is recommended even if the target is well grounded through another path.

## Probe Connector

Connect the probe by aligning the red dots on the connectors and inserting the probe connector.

**CAUTION:** To disconnect the probe, pull on the knurled barrel of the probe connector to release it. DO NOT PULL ON THE CABLE.

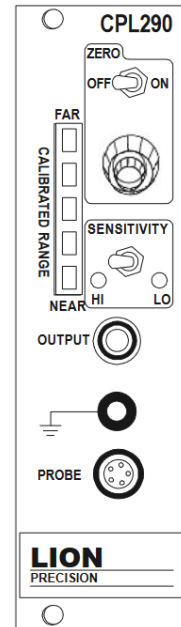

## 8 Multiple channel measurements

Using multiple sensors on the same target requires that the sensor excitation voltages be synchronized. This is done automatically by the Elite Series enclosures. In addition, even and odd channel numbers use inverted (180°) excitation voltages. This eliminates offset and scale errors that may otherwise occur with poorly grounded targets such as semiconductors. For details on use with ungrounded targets and the advantage of inverted excitation voltages, refer to Lion Precision TechNote LT03-0022 Capacitive Sensors and Ungrounded Targets, available at [www.lionprecision.com](http://www.lionprecision.com); click on Technical Library.

### 8.1 CPL190/290 specifications<sup>1</sup>

Linearity Error	±0.2% F. S. or better, dependent on calibration
Error Band	±0.3% F. S. or better, dependent on calibration
Standard Bandwidth (-3 db)	15 kHz -10%+30%
Coarse Zero Adjustment Range	+10 VDC
Fine Zero Adjustment Range	+1 VDC
Meets ANSI/ASME B5.54 Standard	Yes
Probe Interchangeability	Typical sensitivity variation for same probe model: 10%
Operating Temperature	4°-50°C
Thermal Stability	0.02% F.S./°F, 0.04% F.S./°C
Typical Oscillator Frequency	Probe cable < 12 feet: 1 MHz Probe cable > 12 feet: 500 kHz
Output Impedance	0 Ω
Output Max Voltage	±13.5 VDC
Output Max Current	10 mA

<sup>1</sup>These specifications are typical for standard components and calibrations. Customizations can effect performance. Check the calibration sheet shipped with the product for specific details on your system.

In high EMI environments (10 V/m), output noise may rise to 0.2 VRMS (1% resolution) and DC output may shift.

Last update: 2022-05-13

## 9 Changing CPL190/290/490 bandwidth settings

The CPL190/290/490 provides a two-position DIP switch for setting bandwidth.

*Note: When changing bandwidth, change all modules in the system. Bandwidth is a system-wide setting; bandwidth switches on the modules within a system are interconnected.*

*All of the bandwidth switches must be in the same position for predictable results.*

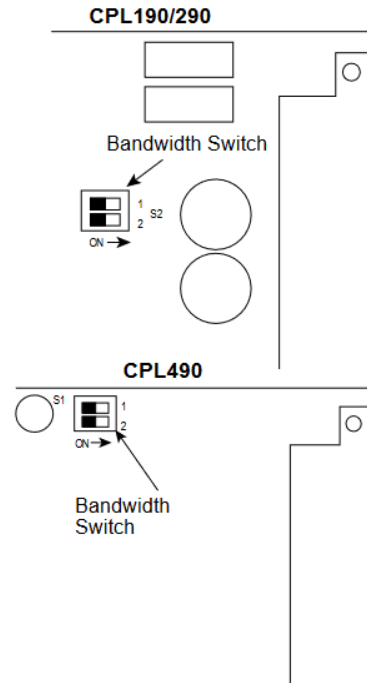

This switch is located as shown in the drawings at the right. The following table shows the bandwidths available and their associated dip switch settings.

Bandwidths listed are approximate. Actual values depend on the probe and calibration.

CPL190/290 (S2)	CPL490 (S1)	2	1	Notes
15 kHz	50 kHz	OFF	OFF	Computer control of bandwidth requires this setting (OFF, OFF)
10 kHz	15 kHz	OFF	ON	
1 kHz	10 kHz	ON	OFF	
100 Hz	1 kHz	ON	ON	

### Bandwidth DIP Switch Access

Be careful to only change switches and jumpers as directed in this manual. Any other changes will affect the calibration of the module.

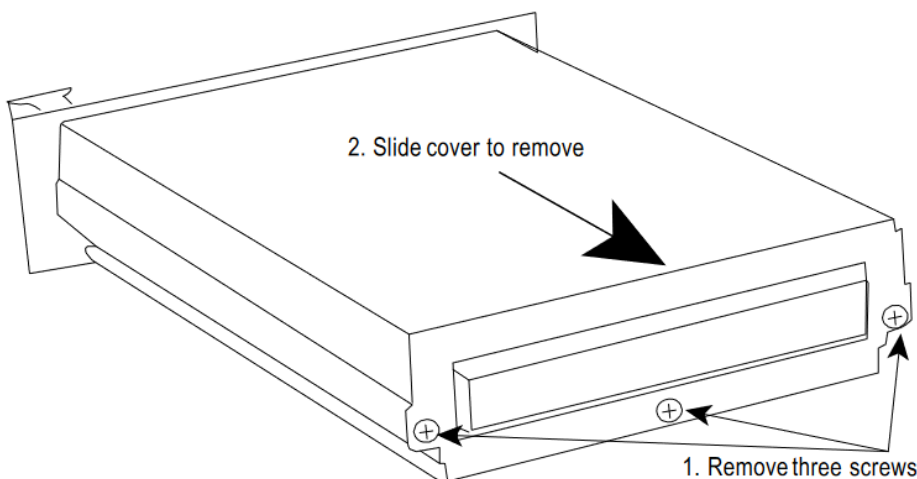



Last update: 2022-05-13

## 10 Elite Series Enclosures

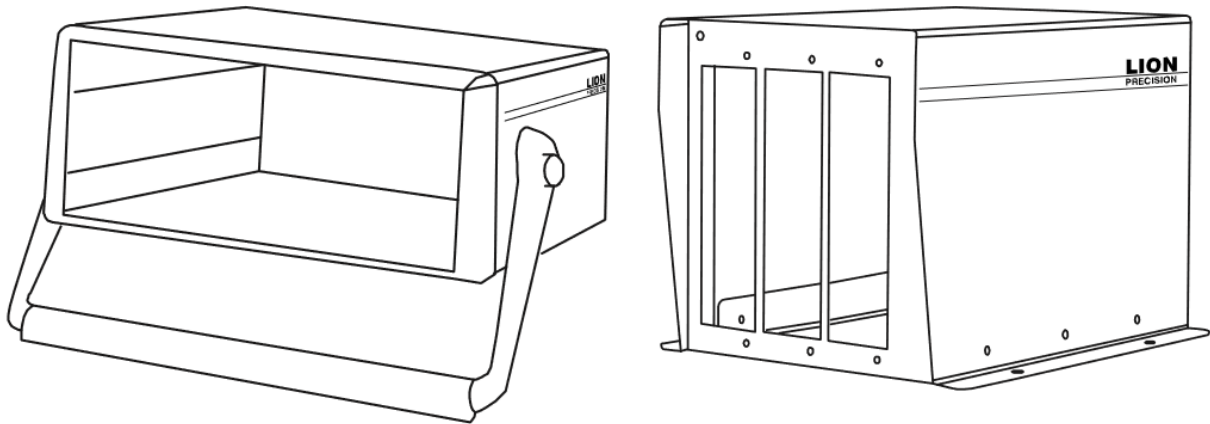

Elite Series enclosures provide housing and critical signals to Elite Series modules. Sensor output signals are available via a rear-panel high-density connector which is configured for direct connection to National Instruments™ data acquisition hardware.

The specific Elite Series enclosure model number indicates the maximum number of slots available for plug-in modules as well as other features:

Model	Number of Module Slots	Input Power	Tin-up Handle	Mounting Flanges
EN191	1	±15 VDC	NO	YES
EN192	2	±15 VDC	NO	YES
EN193	3	±15 VDC	NO	YES
EN196	6	100-250 VAC		
50/60 Hz	YES	NO		

### Power Specifications

Model	Power Input	Notes
EN191, EN192, EN193	±15 VDC ±5%, 400mA Max  (A power supply is included with orders)	To maintain maximum resolution use a linear power supply or a power supply with switching frequency greater than 100 kHz such as Lion Precision Power Supply P014-5040.  To maintain CE compliance, use the included power supply or equivalent CE compliant model.
EN196, EN198	100-250 VAC, 50/60 Hz, 250 VA Maximum	

Last update: 2022-05-13

## 11 EN191, EN192, EN193 power connector

Pin	Connection
1	Ground
3	- 15 VDC
4	+ 15 VDC

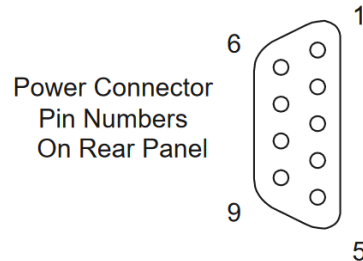

### External Power Supply

EN191, EN192, and EN193 systems include an external power supply. The supply has a connector which allows direct connection to the enclosure.

This supply features a high-frequency (100kHz) switching supply. The high switching frequency allows the sensing modules to operate at maximum resolution.

<b>DC Output Voltage</b>	+15 VDC ; 2.0 A -15 VDC ; 1.0 A
<b>AC Input Voltage</b>	100-240 VAC, 50/60 Hz, 1.35 A max

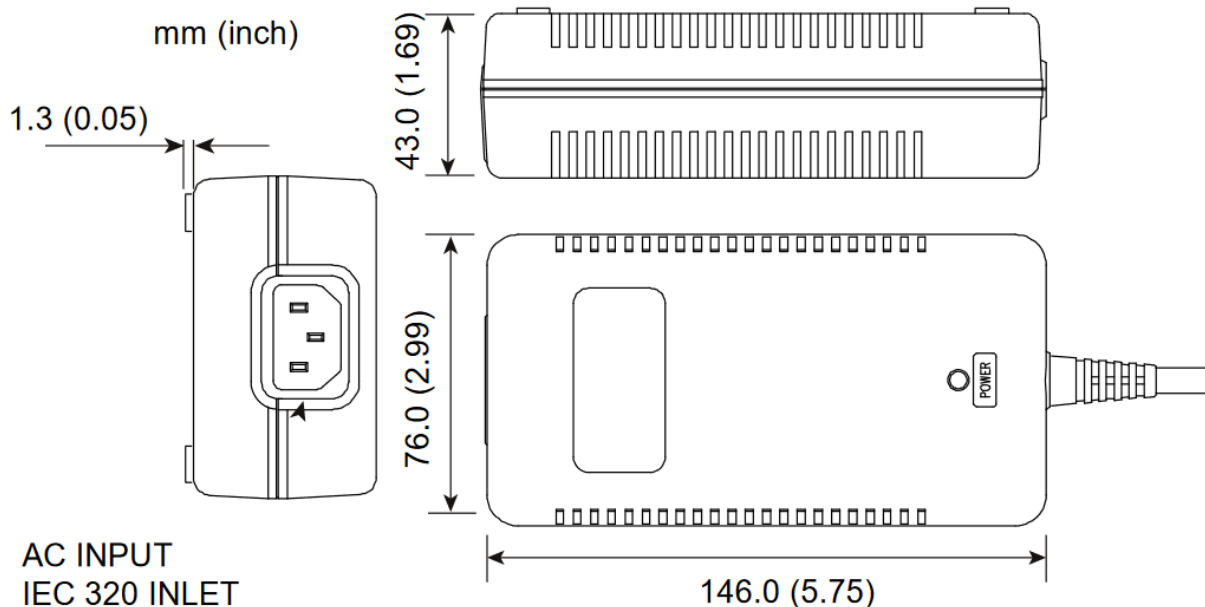

Last update: 2022-05-13

## 12 DAQ connector pinout

All unlisted pins are reserved for proprietary use by Lion Precision and should not be connected to external contacts.

Pin	Output Signals
11	Encoder
12, 13, 15, 18, 53	Digital Ground
29, 32, 64, 67	Analog Ground
23	– Analog Out; Channel 8
25	+ Analog Out; Channel 7
26	– Analog Out; Channel 6
28	+ Analog Out; Channel 5
30	+ Analog Out; Channel 4
31	– Analog Out; Channel 3
33	+ Analog Out; Channel 2
34	– Analog Out; Channel 1
57	+ Analog Out; Channel 8
58	– Analog Out; Channel 7
60	+ Analog Out; Channel 6
61	– Analog Out; Channel 5
63	– Analog Out; Channel 4
65	+ Analog Out; Channel 3
66	– Analog Out; Channel 2
68	+ Analog Out; Channel 1

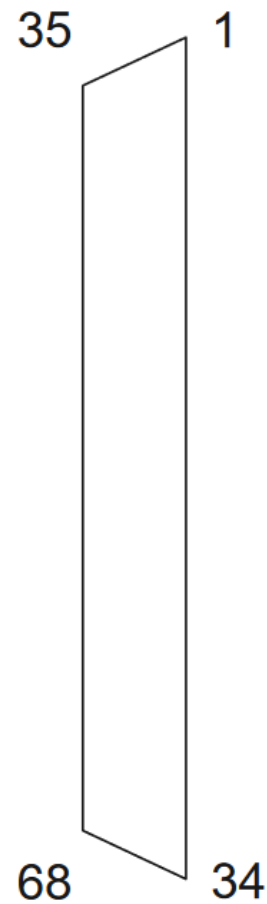

DAQ Connector  
Pin Numbers

Last update: 2022-05-13

### 13 Mechanical specifications: EN196, EN198

Model	A
EN196	10.1" 257 mm
EN198	14.3" 364 mm

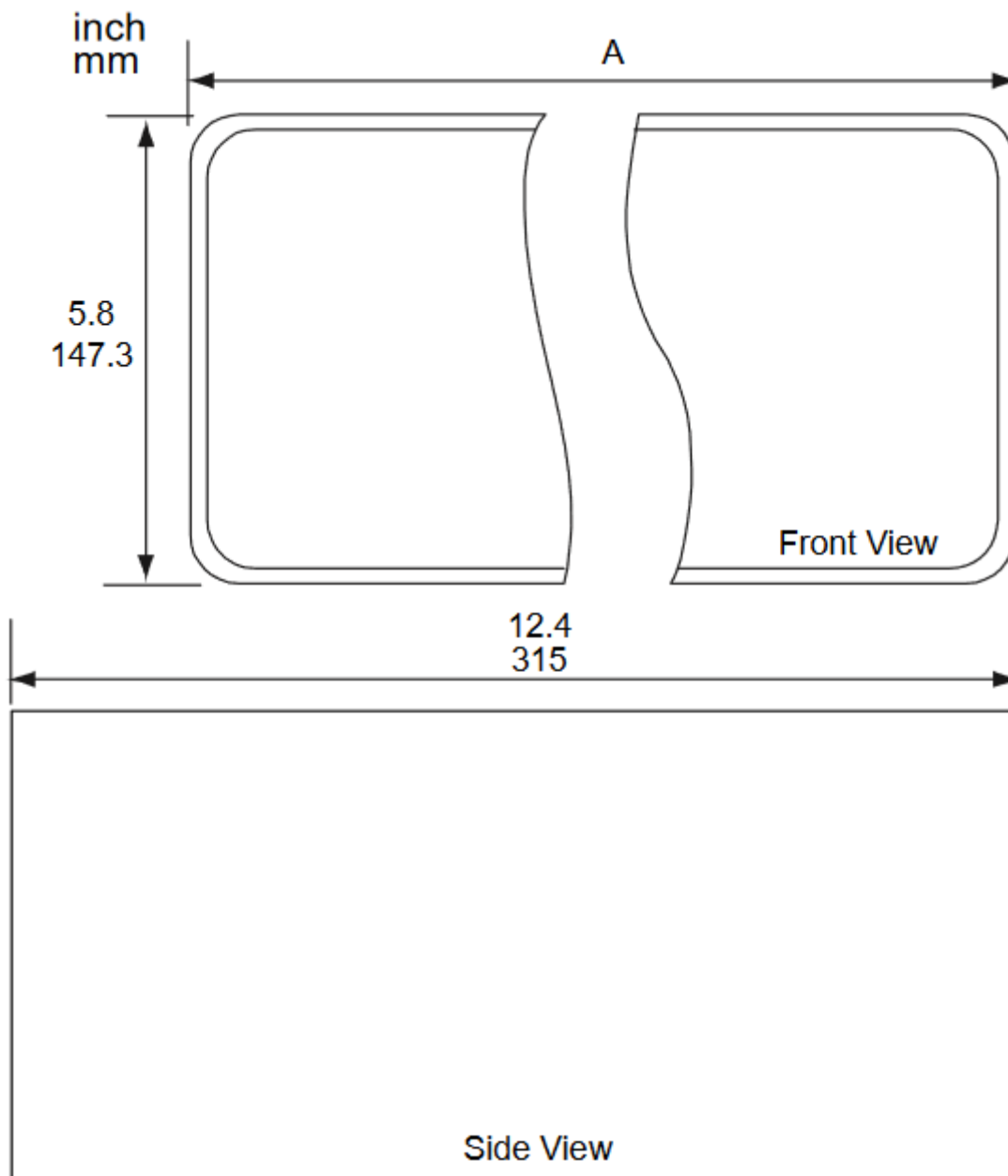

Last update: 2022-05-13

Mechanical specifications: EN191, EN192, EN193

Model	A	B	C
EN191	3.33" 84.6 mm	2.606" 66.2 mm	3.806" 96.7 mm
EN192	4.73" 120.1 mm	4.006" 101.8 mm	5.206" 132.2 mm
EN193	6.13" 155.7 mm	5.406" 137.3 mm	6.606" 167.8 mm

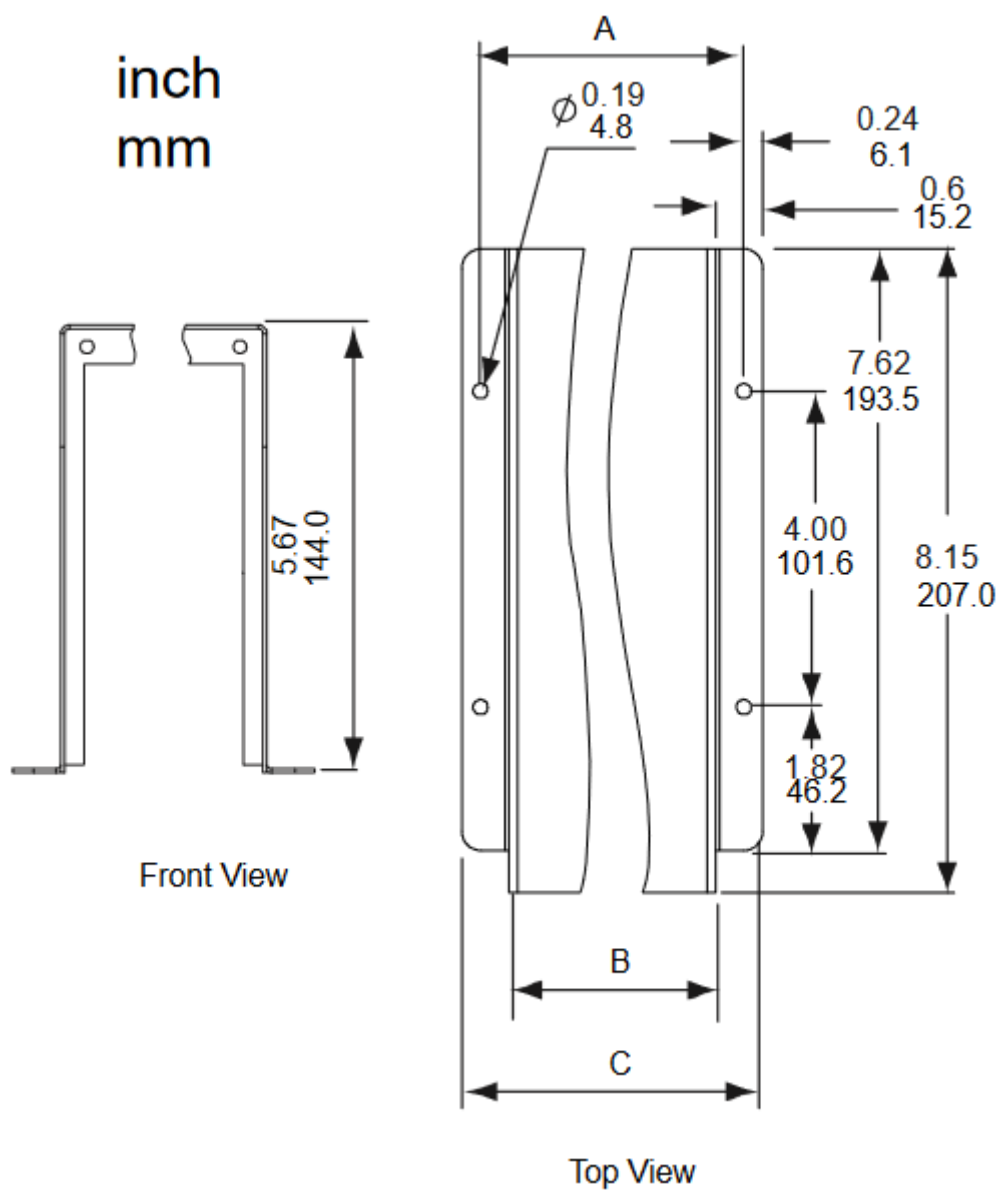

Last update: 2022-05-13
 

---

## 14 Air-Bearing C-LVDT: Capacitive LVDT - type contact sensor

The Air-Bearing C-LVDT converts a capacitive sensor using a standard capacitive probe into a high-precision contact displacement sensor similar to an LVDT. The capacitive probe is installed in the top of the C-LVDT body where it measures the location of a target connected on the inside end of the stylus. The C-LVDT uses a linear air-bearing for nearly friction-free movement of the stylus, and the porous carbon air bearing is square to prevent stylus rotation. Adjustable air pressure for extending the stylus provides for contact forces less than one gram, and the CLVDT features a retraction port through which application of air pressure will retract the stylus.

The C-LVDT uses an interchangeable diamond tip. Diamond has been selected over ruby for the following reasons:

- Low Friction - Side forces cause less lateral deflection from moving targets and less hysteresis on direction reversal.
- Highly Polished Surface - Diamond accepts and holds a high polish, minimizing the possibility of scratching the measured surface.
- Minimal Wear - Increased accuracy and longer life.

### Contact Force Adjustment

There is a contact force adjustment screw located on the end of the probe body near the cable exit. Use a 1/16" hex key to turn the adjustment clockwise to increase the contact force or counter clockwise to decrease it. Contact force is also a function of the air pressure applied to the C-LVDT. To maintain constant contact force, supplied air pressure must be held constant.

### Air Exhaust

The 0.1" slot around the body near the top of the C-LVDT is where air is exhausted. Do not clamp the C-LVDT over this ring. The ring must remain at least partially clear at all times for proper operation of the C-LVDT.

### Specifications

Measurement Range	0.5 mm, 0.020 inch
Contact Force	0.2 g to 100 g
Radial Stiffness	< 0.25 $\mu\text{m/g}$
Bearing	Linear, porous air bearing
Diamond Tip	Radius: 3.175 mm, 0.125 inch Mount: 4-48AGD Thread
Weight of Moving Mass	4.2 g
Air Connection	1/16 inch ID flexible tubing
Air Consumption	3-7 lpm, 0.10-0.25 cfm
Operating Air Pressure	420-480 kPa, 60-70 psi
Air Requirement	Dry, filtered to less than 5 $\mu\text{m}$

Last update: 2022-05-13

## 15 Air-Bearing C-LVDT: Mechanical detail

